

Ersatzteilliste
Spare parts catalogue
Liste de pièces

B7.5 **Filtersystem P61**
B7.5 **Filter system P61**
B7.5 **Système de filtrage P61**



Baugruppe	Assembly	Groupe d'assemblage	Seite/page
Öl- und Wasserabscheider	Oil and water separator	Séparateur d'huile et d'eau	B7.5- 1
Feinnachreiniger o. SECURUS	Purifier without SECURUS	Epurateur sans SECURUS	B7.5- 2
Feinnachreiniger m. SECURUS	Purifier with SECURUS	Epurateur avec SECURUS	B7.5- 3
Feinnachreiniger m. SECURUS/COMP-TRONIC	Purifier with SECURUS/COMP-TRONIC	Epurateur avec SECURUS/COMP-TRONIC	B7.5- 4
Druckhalte-/Rückschlagventil	Pressure maintaining/non-return valve	Soupape du maintien de pression et clapet anti-retour	B7.5- 5

Änder.-Nr. Change no. No. de change	Datum Date	Änderung	Change	Changement
0	18.10.85	Grundaussgabe	Basic edition	Edition de base
1	28.01.86	Manometer, glyzeringedämpft	Pressure gauge, glycerine damped	Manomètre amorti en glycerine
2	01.05.87	Halterung für SECURUS, Druckhalte-/Rückschlagventil	bracket for SECURUS, Pressure maintaining/non-return valve	Fixation pour SECURUS, Clapet de maintien de pression anti-retour
3	06.08.90	Öl- und Wasserabscheider, Entlüftungsventil	Oil and water separator, venting valve	Séparateur pour SECURUS, clapet de décharge
4	25.08.93	COMP-TRONIC-Sensorkopf	COMP-TRONIC sensor head	Capteur COMP-TRONIC
5	01.03.96	Druckhalte-Rückschlagventil	Pressure maintaining/non-return valve	Soupape de maintien de pression anti-retour

Wichtige Hinweise für Teilebestellung:

Bestell-Nr., die mit der Ziffer 0 beginnen, bezeichnen Baugruppen, die komplett geliefert werden. Teile ohne Bestell-Nr. sind nur zur Information für die Montage aufgeführt. Sie sind nicht als Ersatzteil erhältlich. Bei Ersatzteilbestellungen erwarten Sie unsere richtige Lieferung; deshalb benötigen wir von Ihnen folgende Angaben (siehe unten gezeigtes Typenschild):

1. Modellbezeichnung, Fabrik-Nr. sowie Fertigungsstand von Anlage/Block
2. Stückzahlen
3. Benennung und Best.-Nr. des gewünschten Teils

Bestell-Beispiel:

Für Kompressorblock ...
Fabrik-Nr. 524-0528/1/2 drei Dichtungen
8263-090



Wartungssätze

- a = Wartungssatz 500 h
- b = Wartungssatz 1000 h
- c = Wartungssatz 2000 h

In den Spalten sind die im entsprechenden Satz enthaltenen Teile angekreuzt. Bitte beachten, daß die höheren Sätze die untergeordneten nicht beinhalten, d.h. für eine 4000-Stunden-Wartung wird 1x Satz a, 1x Satz b und 1x Satz c benötigt.

**Anmerkungen zur Identifikation:
Remarks for identification:
Remarques pour l'identification:**

Modell/Model/Modèle		Fabrik-Nr./Serial no./Numéro de série	
[]		[]	
Volumenstrom m ³ /min	[]	Jahr/Year	[]
Free air delivery Scfm	[]	n/min./r.p.m.	[]
Betriebsüberdruck bar	[]	kW	[]
Max. working press. psig	[]	CE	
		KB 73708	
		Fertigungsstand / Modification no. / No. de modification	
		Anlage/Unit/Groupe	
		Kompressorblock / Compressor block / Bloc compresseur	

Important notes for spare parts orders:

Part nos. beginning with digit 0 indicate parts available as complete assemblies. Parts without part no. are indicated for assembly reference, only. These parts are not available as single parts. When placing an order for spare parts, please give the following items so as to ensure our correct delivery (see identification plate shown below):

1. Model, serial no. as well as design standard of unit/block
2. Quantity required
3. Name and part no.

Example for order:

For compressor block ...
serial no. 524-0528/1/2, three gaskets
8263-090



Maintenance kit

- a = Maintenance kit 500 h
- b = Maintenance kit 1000 h
- c = Maintenance kit 2000 h

The columns contain the parts that are included in the respective parts set. Please note that the higher graded kits do not include the lower ones, i.e. for a 4000 hours maintenance, one kit a, one kit b plus one kit c are required.

Avis important pour la commande de pièces:

Les nos. de commande commençant par le chiffre 0 indiquent les pièces livrées au complet. Les pièces sans no. de commande sont indiquées uniquement pour information de montage. Elles ne sont pas livrées individuellement. Pour que la livraison de pièces de rechange corresponde à la commande, veuillez bien nous fournir les données suivantes (voir plaque d'identité ci-dessous):

1. Modèle, no. de série et standard de construction de bloc compresseur/groupe
2. Quantité désirée
3. Dénomination et no. de commande de la pièce désirée

Exemple de commande:

Pour bloc compresseur ...
no. de série 524-0528/1/2, trois joints no. de cde. 8263-090



Kits de pièces d'entretien :

- a = Kit d'entretien 500 h
- b = Kit d'entretien 1000 h
- c = Kit d'entretien 2000 h

Les pièces contenues dans les kits correspondants sont marquées d'une croix dans les colonnes. Veuillez observer que les kits supérieurs ne contiennent pas les kits subordonnés, c'est-à-dire pour un entretien de 4000 heures il faut avoir 1x kit a, 1x kit b et 1x kit c.



ACHTUNG

Nur Schrauben und Stiftschrauben der Qualität 8.8 verwenden!



ATTENTION

Use only screws and studs in quality 8.8! This quality is equivalent to SAE J 429 grade 5.



ATTENTION

N'utiliser que des vis et des goujons filetés de la qualité 8.8!

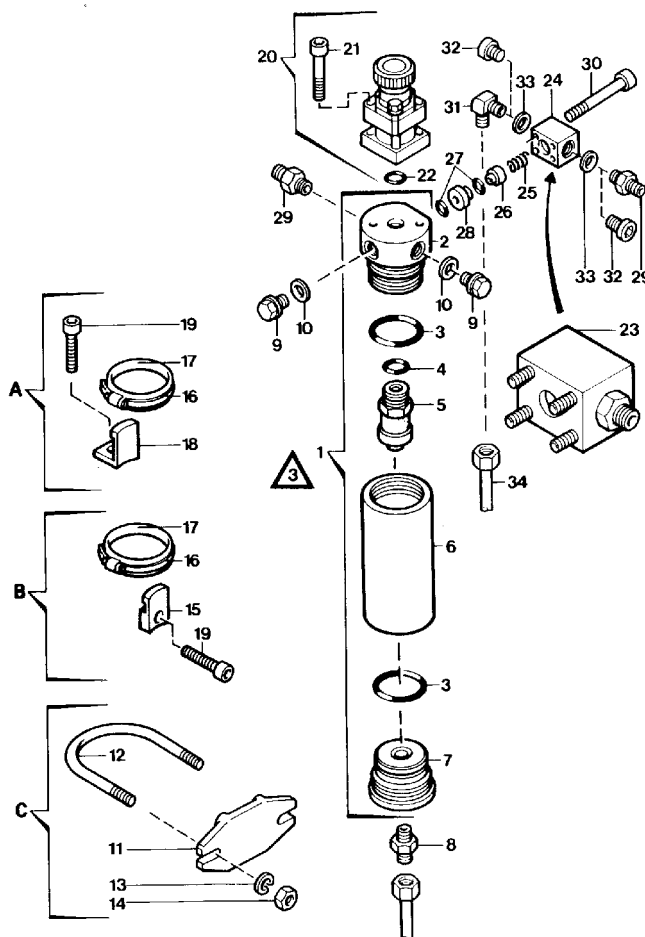
 Wartungssätze
 Maintenance kits
 Kits d'entretien

 Bildtafel
 Figure
 Planche

 B7.5- 1
 B7.5- 1
 B7.5- 1

 Öl- und Wasserabscheider
 Oil and water separator
 Séparateur d'huile et d'eau

Klasse/ Class/ Classe			Pos.	Bestell-Nr. Part No. No. de cde.	Anz. Qty. Qté.	Benennung	Designation	Dénomination	Gew. Weight Poids (kg)	Abmessungen Dimensions Dimensions
a	b	c								
			1	090058	1	Öl- und Wasserabscheider kpl.	Oil and water separator assy.	Séparateur d'huile et d'eau cpl.		
			2	90057*	1	Verschraubung, oben	Plug, top	Chapeau de séparateur		
X			3	N4586	2	O-Ring	O-ring	Joint torique		Ø59,92x3,53
			4	N15133	1	O-Ring	O-ring	Joint torique		Ø28,24x2,62
X			5	061860	1	Filterpatrone	Filter cartridge	Cartouche filtrante		
			6	90055*	1	Filtergehäuse	Filter housing	Corps de séparateur		
			7	90056*	1	Filterboden	Filter base	Fond de séparateur		
			8	N3816	1	Gerade Rohrverschr	Male connector	Raccord droit mâle		GE 6-PSR-ed, G 1/4"
			9	N52	2	Verschlußschraube	Plug	Bouchon fileté		G 1/4", DIN 910
			10	N1316	2	Dichtung	Gasket	Joint		A14x20, DIN 7603
			11	63599	1	Filterauflage	Filter support	Support de séparateur		
			12	63600	1	Befestigungsbügel	U-boit	Etrier de fixation		
			13	N108	2	Federring	lock washer	Rondelle élastique		Ø8, DIN 127
			14	N57	2	Sechskantmutter	Hex. nut	ecrou hex.		M8, DIN 934
			15	61875	1	Filterhalter	Filter bracket	Fixation de séparateur		
			16	N15499	1	Schnecken-gew.-schelle	Clamp	Collier		
			17	N15500	1	Gummiprofil	Rubber	Profilé en caoutchouc		
			18	61646	1	Befestigungswinkel	Bracket	Fixation		
			19	N3859	1	Innensechskantschraube	Allen screw	Vis à six pans creux		M6x25, DIN 6912
			20	059410	1	Sicherheitsventil	Safety valve	Soupape e sûreté		
			21	N150	2	Innensechskantschraube	Allen screw	Vis à six pans creux		M8x60, DIN 912
			22	N4882	1	O-Ring	O-ring	Joint torique		Ø16x2
			23	063991	1	Rückschlagventil kpl.	Non-return valve assy.	Clapet anti-retour cpl.		
			24	63840	1	Ventilkörper	Valve body	Corps de clapet		
			25	3089	1	Feder	Spring	Ressort		
			26	056674	1	Ventilkoiben	Valve piston	Piston de clapet		

*

Nur zusammen lieferbar

Only available together

Ne sont livrées qu'ensemble

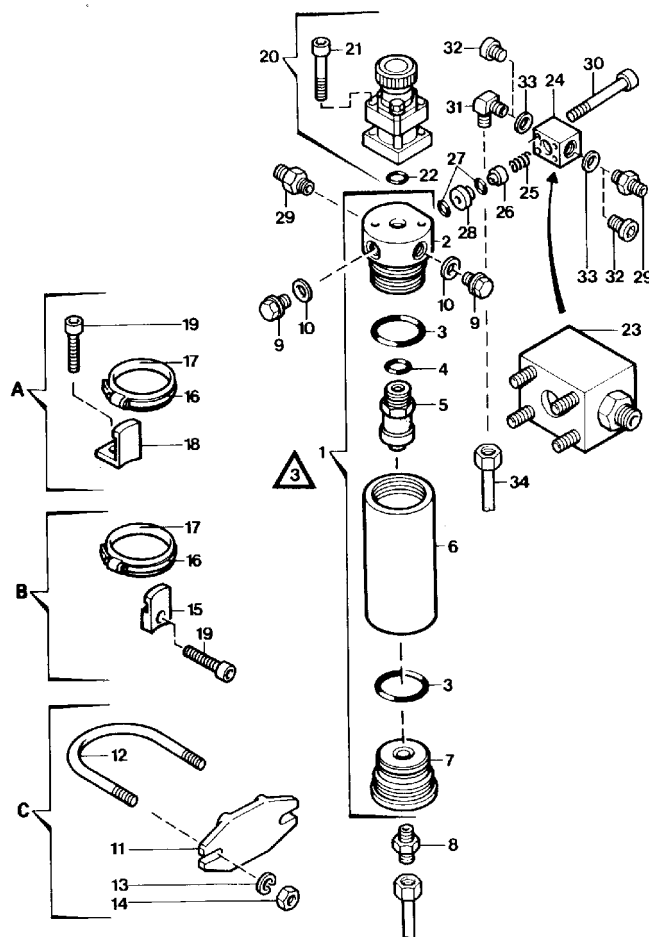
 Wartungssätze
 Mainenance kits
 Kits d'entretien

 Bildtafel
 Figure
 Planche

 B7.5- 1
 B7.5- 1
 B7.5- 1

 Öl- und Wasserabscheider
 Oil and water separator
 Separateur d'huile et d'eau

Klasse/ Class/ Classe			Pos.	Bestell-Nr. Part No. No. de cde.	Anz. Qty. Qté.	Benennung	Designation	Dénomination	Gew. Weight Poids (kg)	Abmessungen Dimensions Dimensions
a	b	c								
			27	N4178	2	O-Ring	O-ring	Joint torique		Ø17,12x2,62
			28	63843	1	Rückschlagventilsitz	Valve seat	Siège de clapet anti-ret.		
			29	N3811	1	Gerade Rohrverschr.	Male connector	Raccord droit mâle		GE 8-PSR, G1/4"
			30	N724	4	Innensechskantschraube	Allen screw	Vis à six pans creux		M6x40, DIN 912
			31	N3044**	1	Winkelrohrverschraubung	Male elbow	Raccor coudé mâle		WE 8-PSR, G 1/4"
			32	N4570**	2	Verschlußschraube	Plug	Bouchon fileté		G 1/4", DIN 908
			33	56983	2	Dichtung	Gasket	Joint		
			34	N3619***	1	Verbindungsleitung	Connecting tube	Conduite de connexion		Ø8x1,5x, DIN 2464

**

 wahlweise
 Meterware

 optional
 Piece goods; specify length
 upon order

 optionnel
 Marchandise au mètre; indiquer la longueur à la commande

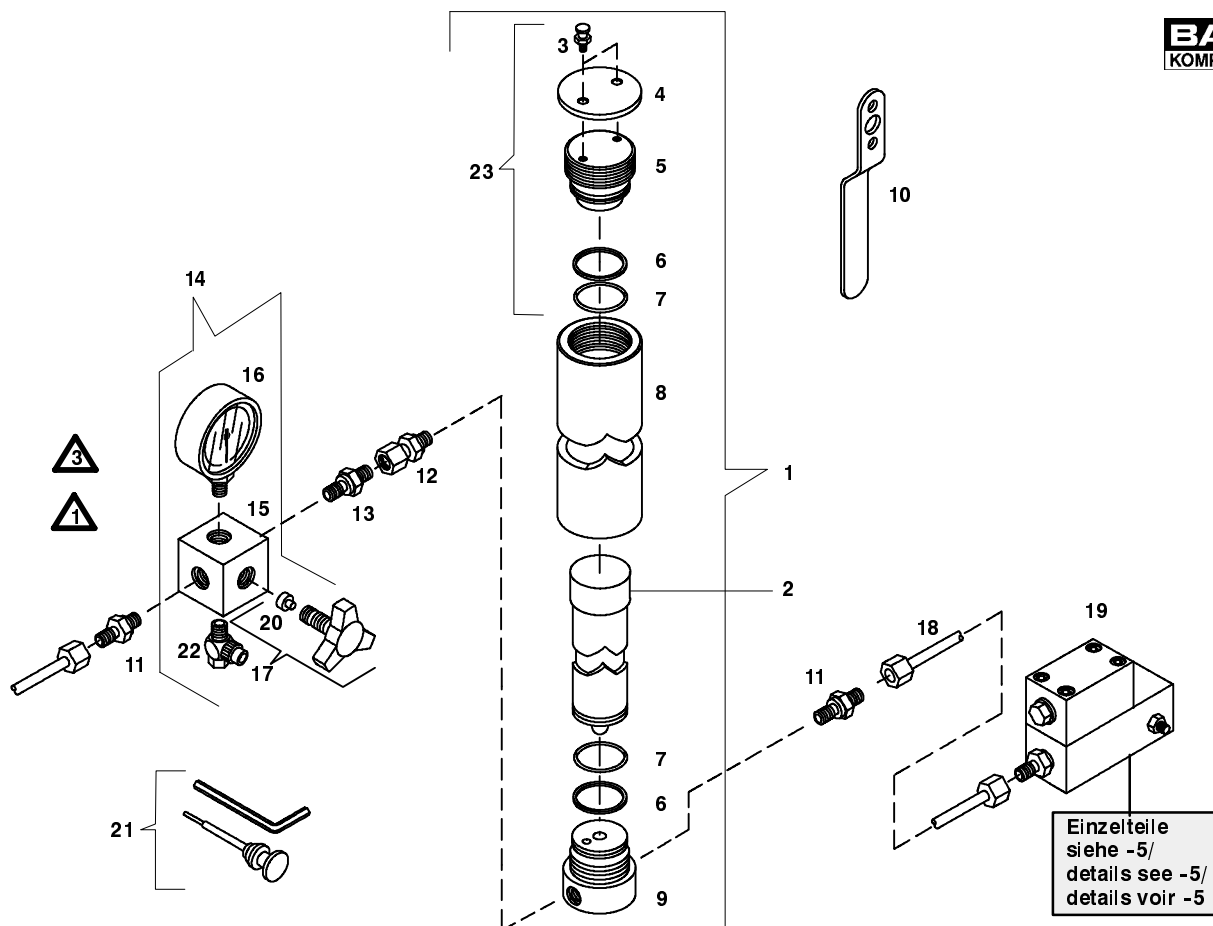
 Wartungssätze
 Maintenance kits
 Kits d'entretien

 Bildtafel
 Figure
 Planche

 B7.5- 2
 B7.5- 2
 B7.5- 2

 Feinnachreiniger o. SECURUS
 Purifier without SECURUS
 Epurateur sans SECURUS

Klasse/ Class/ Classe			Pos.	Bestell-Nr. Part No. No. de cde.	Anz. Qty. Qté.	Benennung	Designation	Dénomination	Gew. Weight Poids (kg)	Abmessungen Dimensions Dimensions
a	b	c								
			1	061082	1	HD-Filter kpl. o. Patrone	HP filter assy. without cartridge	Epurateur HP cpl. sans cartouche		
			2	058826	1	Filterpatrone MS-AC-MS	Filter cartridge MS-AC-MS	Cartouche filtrante MS-AC-MS		
			3	12293	2	Befestigungsschraube	Fastening screw	Vis de fixation		
			4	66693	1	Schutzdeckel	Cover	Couvercle		deutsch
				66694	1	Schutzdeckel	Cover	Couvercle		english
				66695	1	Schutzdeckel	Cover	Couvercle		français
			5	62820*	1	Verschraubung, oben	Plug, top	Chapeau de filtre		
X			6	N4736	2	Stützring	Backup ring	Bague d'appui		
X			7	N4735	2	O-Ring	O-ring	Joint torique		
			8	61075*	1	Filtergehäuse	Filter housing	Corps de filtre		
			9	61078*	1	Filterboden	Filter base	Fond de filtre		
			10	60074	1	Schlüssel	Key	Clé		
			11	N16265	2	Gerade Rohrverschr.	Male connector	Raccord droit mâle		
			12	N15501	1	Einst. ger. Rohrverschr.	Adjustable male conn	Raccord droit mâle orient.		
			13	N4024	1	Gerade Rohrverschr.	Male connector	Raccord droit mâle		
			14	064566	1	Entlüftungsventil	Venting valve	Clapet de décharge		
			15	64486	1	Ventilkörper	Valve body	Corps de clapet		
			16	N16872	1	Manometer	Pressure gauge	Manomètre		
			17	065500	1	Knebelschraube kpl.	Petcock handle assy.	robinet cpl.		
			18	N3619**	1	Verbindungsleitung	Connecting tube	Conduite de connexion		
			19	063838	1	Druckhalte-/Rückschlagventil kpl.	Pressure maint./non-return valve assy.	Clapet de maint. ee press. anti-retour		
			20	64498	1	Joint	Gasket	Joint		
			21	067458	1	Werkzeugsatz f. Knebelschraube	Tool set for petcock handle	Jeu d'outils pour vis à robinet		

*

**

 Nur zusammen lieferbar
 Meterware

 Only available together
 Piece goods; specify length
 upon order

 Ne sont livrés qu'ensemble
 Marchandise au mètre; indiquer la longueur à la commande

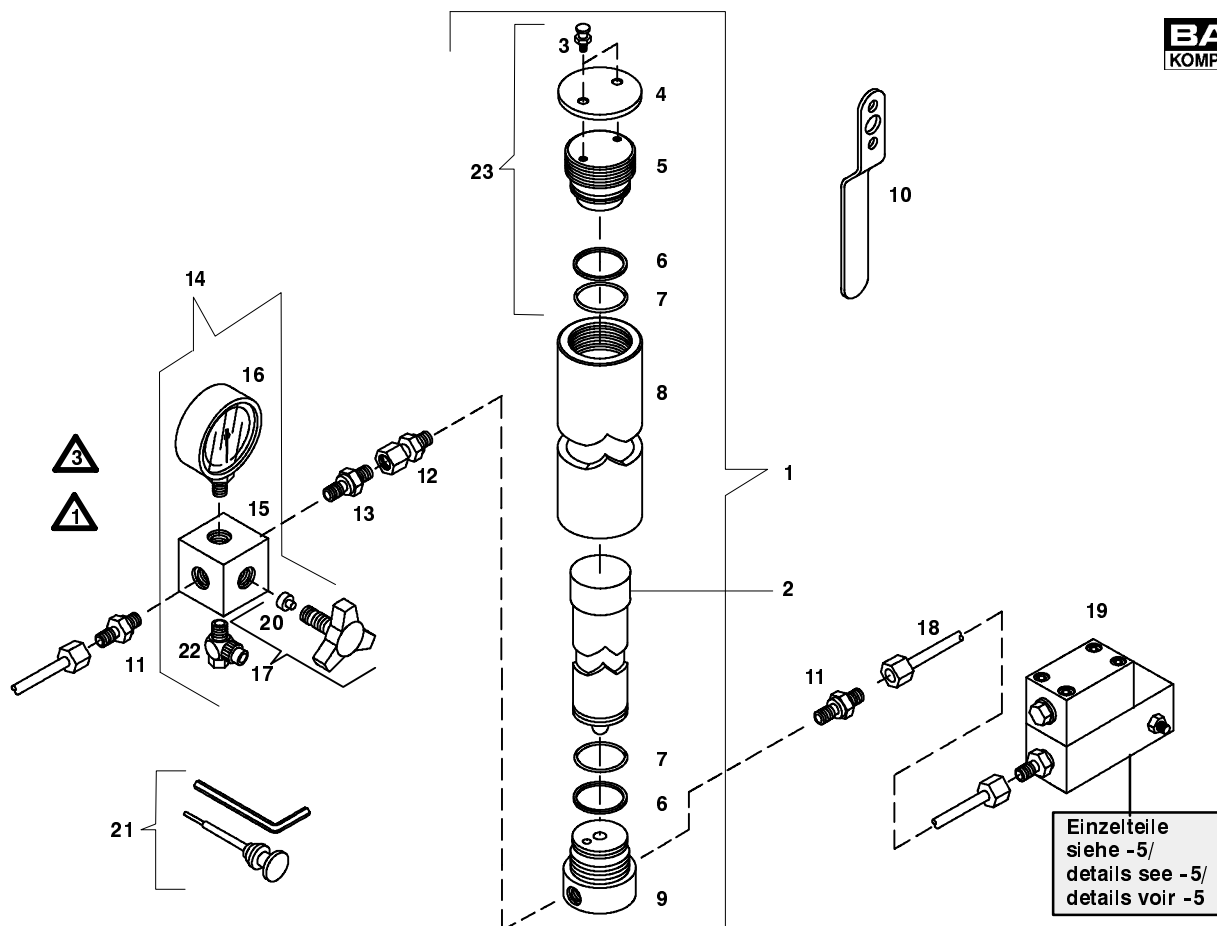

Wartungssätze
Maintenance kits
Kits d'entretien

Bildtafel
Figure
Planche

B7.5- 2
B7.5- 2
B7.5- 2

Feinnachreiniger o. SECURUS
Purifier without SECURUS
Epurateur sans SECURUS

Klasse/ Class/ Classe			Pos.	Bestell-Nr. Part No. No. de cde.	Anz. Qty. Qté.	Benennung	Designation	Dénomination	Gew. Weight Poids (kg)	Abmessungen Dimensions Dimensions
a	b	c								
			22	N16334	2	L-Schnellverschraubung	Male run Tee	Raccord en T renversé		
			23	061231	1	Verschraubung kpl.	Plug assy.	Chapeau cpl.		

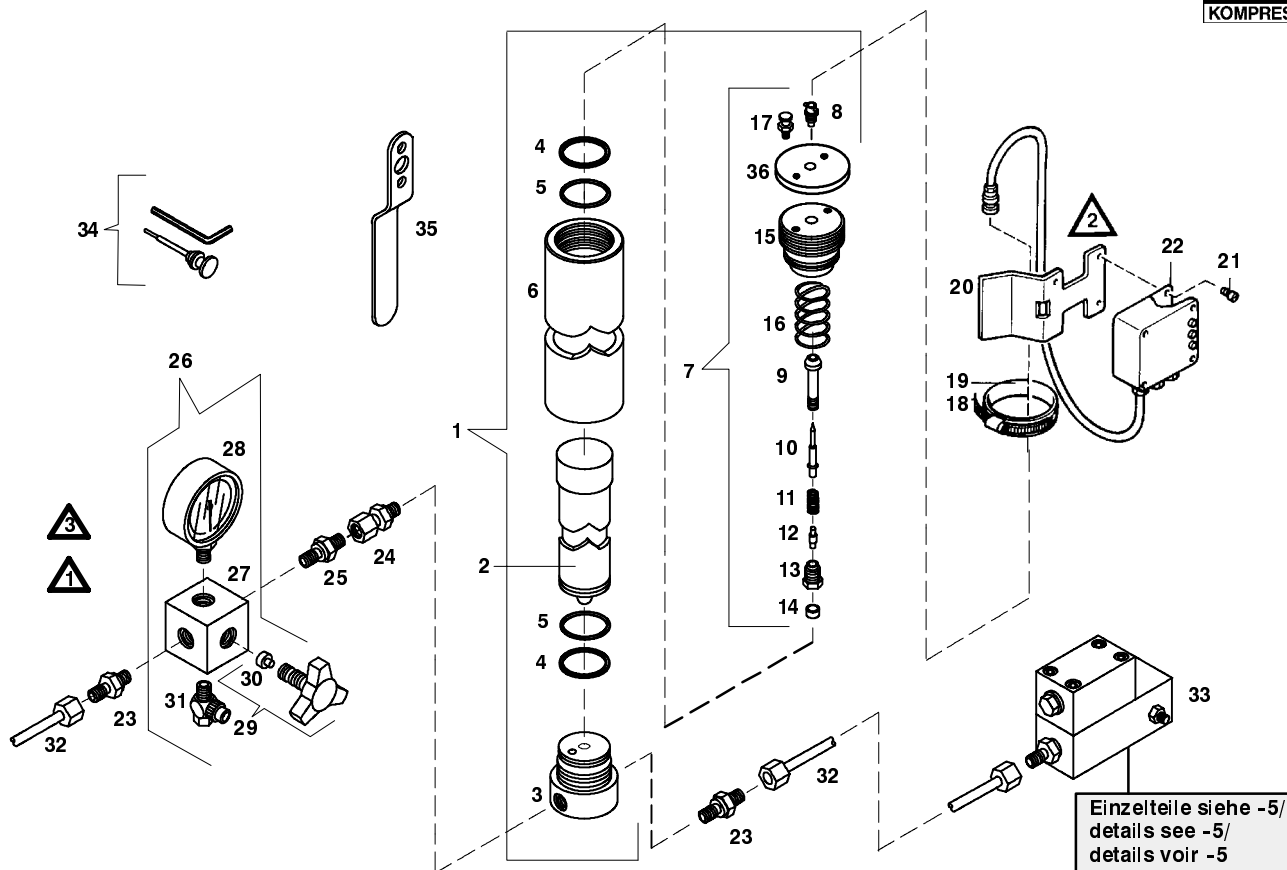

Wartungssätze
 Maintenance kits
 Kits d'entretien

Bildtafel
 Figure
 Planche

B7.5- 3
 B7.5- 3
 B7.5- 3

Feinnachreiniger m. SECURUS
 Purifier with SECURUS
 Epurateur avec SECURUS

Klasse/ Class/ Classe			Pos.	Bestell-Nr. Part No. No. de cde.	Anz. Qty. Qté.	Benennung	Designation	Dénomination	Gew. Weight Poids (kg)	Abmessungen Dimensions Dimensions
a	b	c								
			1	061224	1	HD-Filter kpl. o. Patrone	HP filter assy. without cartridge	Epurateur HP cpl. sans cartouche		
			2	060036	1	Filterpatrone MS-AC-MS	Filter cartridge MS-AC-MS	Cartouche filtrante MS-AC-MS		
				060037	1	Filterpatrone MS-AC-MS-HP	Filter cartridge MS-AC-MS-HP	Cartouche filtrante MS-AC-MS-HP		
			3	61078*	1	Filterboden	Filter base	Fond de filtre		
X			4	N4736	2	Stützring	Backup ring	Bague d'appui		
X			5	N4735	2	O-Ring	O-ring	Joint torique		
			6	61075*	1	Filtergehäuse	Filter housing	Corps de filtre		
			7	061230	1	Verschraubung kpl.	Plug assy.	Chapeau cpl.		
			8	N6391**	1	HF-Einbaubuchse	RF socket	Connecteur H.F.		
			9	N6391**	1	Stopfen	Plug	Bouchon		
			10	N6391**	1	Stift	Pin	Goupille		
			11	N6391**	1	Feder	Spring	Ressort		
			12	N6391**	1	Stift	Pin	Goupille		
			13	N6391**	1	Spannschraube	Tension screw	Vis à tension		
			14	N6391**	1	Mutter	Nut	Ecrou		
			15	61076*	1	Verschraubung, oben	Plug, top	Chapeau de filtre		
			16	2181	1	Feder	Spring	Ressort		
			17	12293	2	Befestigungsschraube	Fastening screw	Vis de fixation		
			18	N15499	1	Schneckenengewindesch.	Clamp	Collier		
			19	N15500	1	Gummiprofil	Rubber profile	Profilé en caoutchouc		
			20	65759	1	Halterung	Bracket	Fixation		
			21	N3501	4	Schraube	Srew	Vis		M4x8, DIN 84
			22	N15094	1	SECURUS-Meldegerät	SECURUS indicator unit	Dispos. de surveillance		190 - 250 V

*

**

Nur zusammen lieferbar
 Reparatursatz N6391 nur
 kpl. lieferbar

Only available together
 Repair kit N6391 only available cpl.

Ne sont livrées qu'ensemble
 Kit de réparation N6391 n'est pas livré qu'ensemble

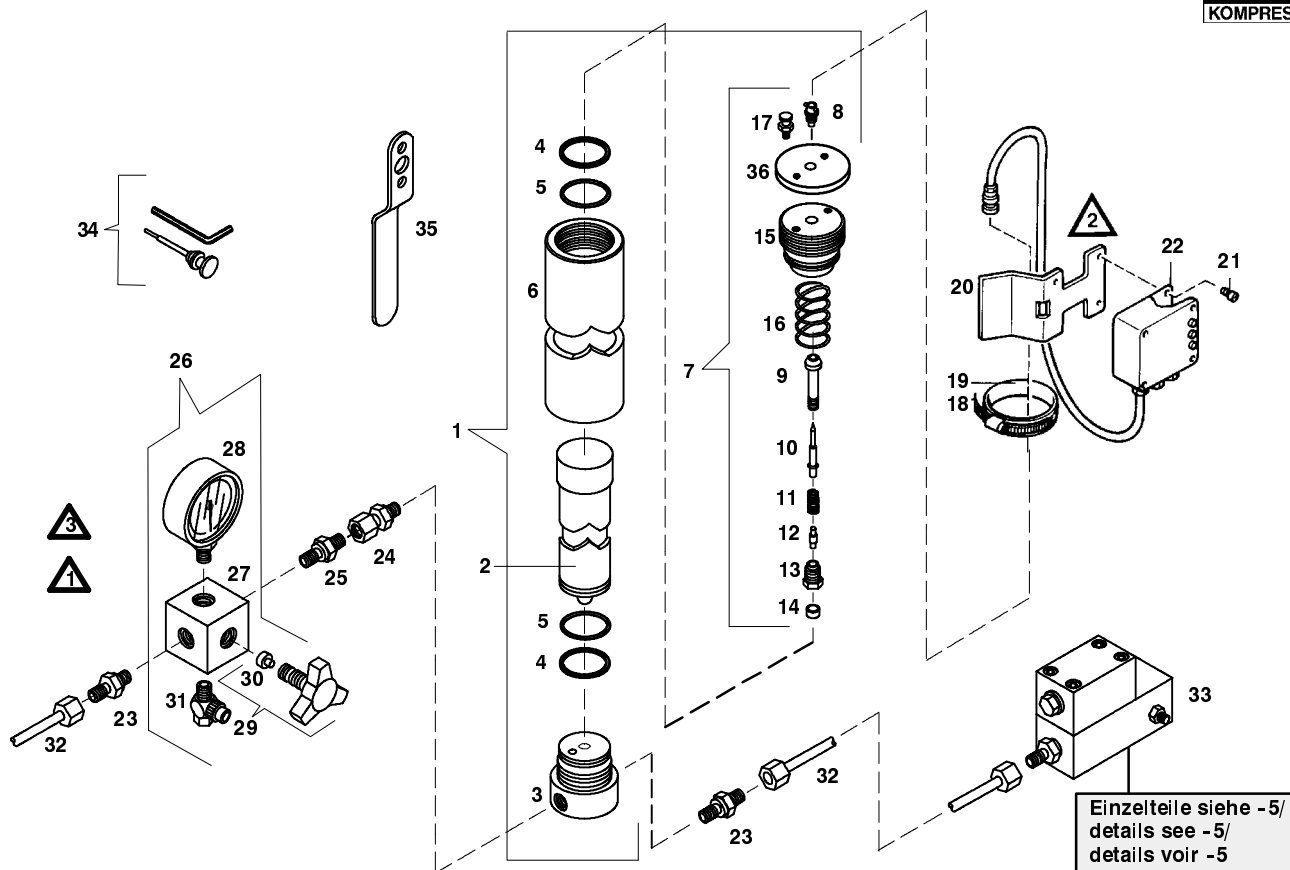
 Wartungsätze
 Maintenance kits
 Kits d'entretien

 Bildtafel
 Figure
 Planche

 B7.5- 3
 B7.5- 3
 B7.5- 3

 Feinnachreiniger m. SECURUS
 Purifier with SECURUS
 Epurateur avec SECURUS

Klasse/ Class/ Classe			Pos.	Bestell-Nr. Part No. No. de cde.	Anz. Qty. Qté.	Benennung	Designation	Dénomination	Gew. Weight Poids (kg)	Abmessungen Dimensions Dimensions
a	b	c								
				N15095	1	SECURUS-Meldegerät	SECURUS indicator unit	Dispos. de surveillance		115 - 127 V
			23	N16265	2	Gerade Rohrverschraub.	Male connector	Raccord droit mâle		GE 8-PSRed, G3/8"
			24	N15501	1	Einstellb. gerade Rohrv.	Adjust. male connector	Raccord droit mâle orient.		evGE 10-PSRed
			25	N4024	1	Gerade Rohrversch.	Male connector	Raccord droit mâle		GE 10-PSRed, G3/8"
			26	064566	1	Entlüftungsventil	Venting valve	Clapet de décharge		
			27	64486	1	Ventilkörper	Valve body	Corps de clapet		
			28	N16872	1	Manometer	Pressure gauge	Manomètre		
			29	065500	1	Knebelschraube kpl.	Petcock handle assy.	robinet cpl.		
X			30	64498	1	Dichtung	Gasket	Joint		
			31	N16334	2	L-Schnelverschraubung	Male run Tee	Raccord en T inversé		
			32	N3619*	1	Verbindungsleitung	Connecting tube	Conduite de connexion		
			33	063838	1	Druckhalte-/Rückschlagventil kpl.	Pressure maint./non-return valve assy.	Clapet de maint. ee press. anti-retour		
			34	067458	1	Werkzeugsatz f. Knebel-schraube	Tool set for petcock handle	Jeu d'outils pour vis à robinet		
			35	60074	1	Schlüssel	Key	Clé		
			36	62844	1	Deckel	Cover	Couvercle		deutsch
				59884	1	Deckel	Cover	Couvercle		englisch
				62849	1	Deckel	Cover	Couvercle		französisch
				62851	1	Deckel	Cover	Couvercle		italienisch

*

Meterware

Piece goods; specify length upon order

Marchandise au mètre; indiquer la longueur à la commande

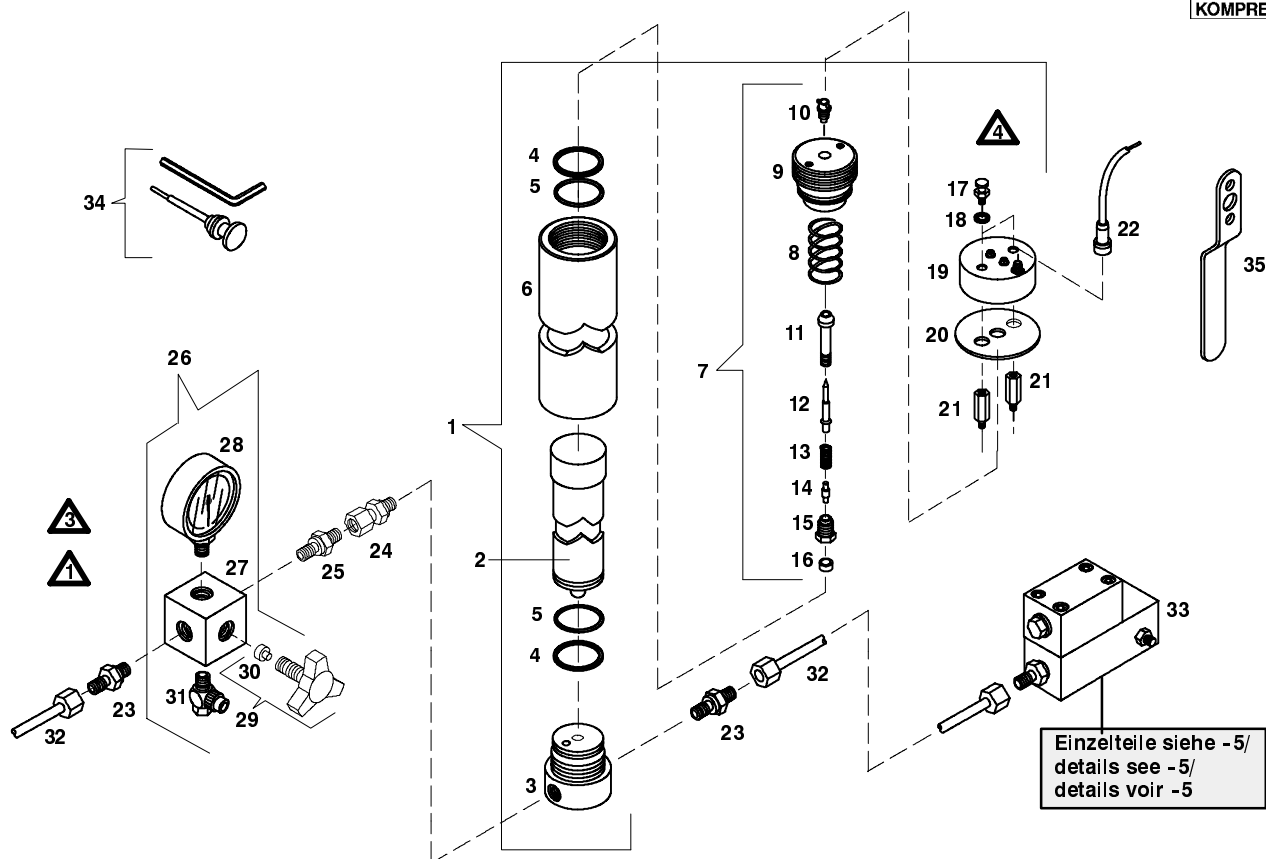

Wartungssätze
 Maintenance kits
 Kits d'entretien

Bildtafel
 Figure
 Planche

B7.5- 4
 B7.5- 4
 B7.5- 4

Feinnachreiniger m. SECURUS/COMP-TRONIC
 Purifier with SECURUS/COMP-TRONIC
 Epurateur avec SECURUS/COMP-TRONIC

Klasse/ Class/ Classe			Pos.	Bestell-Nr. Part No. No. de cde.	Anz. Qty. Qté.	Benennung	Designation	Dénomination	Gew. Weight Poids (kg)	Abmessungen Dimensions Dimensions
a	b	c								
			1	090970	1	HD-Filter kpl. o. Patrone	HP filter assy. without cartridge	Epurateur HP cpl. sans cartouche		
			2	060036	1	Filterpatrone MS-AC-MS	Filter cartridge MS-AC-MS	Cartouche filtrante MS-AC-MS		
				060037	1	Filterpatrone MS-AC-MS-HP	Filter cartridge MS-AC-MS-HP	Cartouche filtrante MS-AC-MS-HP		
			3	61078*	1	Filterboden	Filter base	Fond de filtre		
X			4	N4736	2	Stützring	Backup ring	Bague d'appui		
X			5	N4735	2	O-Ring	O-ring	Joint torique		
			6	61075*	1	Filtergehäuse	Filter housing	Corps de filtre		
			7	061230	1	Verschraubung kpl.	Plug assy.	Chapeau cpl.		
			8	2181	1	Feder	Spring	Ressort		
			9	61076*	1	Verschraubung, oben	Plug, top	Chapeau de filtre		
			10	N6391**	1	HF-Einbaubuchse	RF socket	Connecteur H.F.		
			11	N6391**	1	Stopfen	Plug	Bouchon		
			12	N6391**	1	Stift	Pin	Goupille		
			13	N6391**	1	Feder	Spring	Ressort		
			14	N6391**	1	Stift	Pin	Goupille		
			15	N6391**	1	Spannschraube	Tension screw	Vis à tension		
			16	N6391**	1	Mutter	Nut	Ecrou		
			17	12293	2	Befestigungsschraube	Fastening screw	Vis de fixation		
			18	N20648	2	Dichtung	Gasket	Joint		
			19	090570	1	SECURUS sensor	SECURUS sensor	Senseur SECURUS		
			20	90715	1	Dichtung	Gasket	Joint		
			21	90765	2	Distanzstück	Spacer			
			22	N21762	1	Anschlußstecker	Plug	Connecteur		LifYY 3x0,34 mm, 5 m

*

**

Nur zusammen lieferbar
 Reparatursatz N6391 nur
 kpl. lieferbar

Only available together
 Repair kit N6391 only available cpl.

Ne sont livrées qu'ensemble
 Kit de réparation N6391 n'est pas livré qu'ensemble

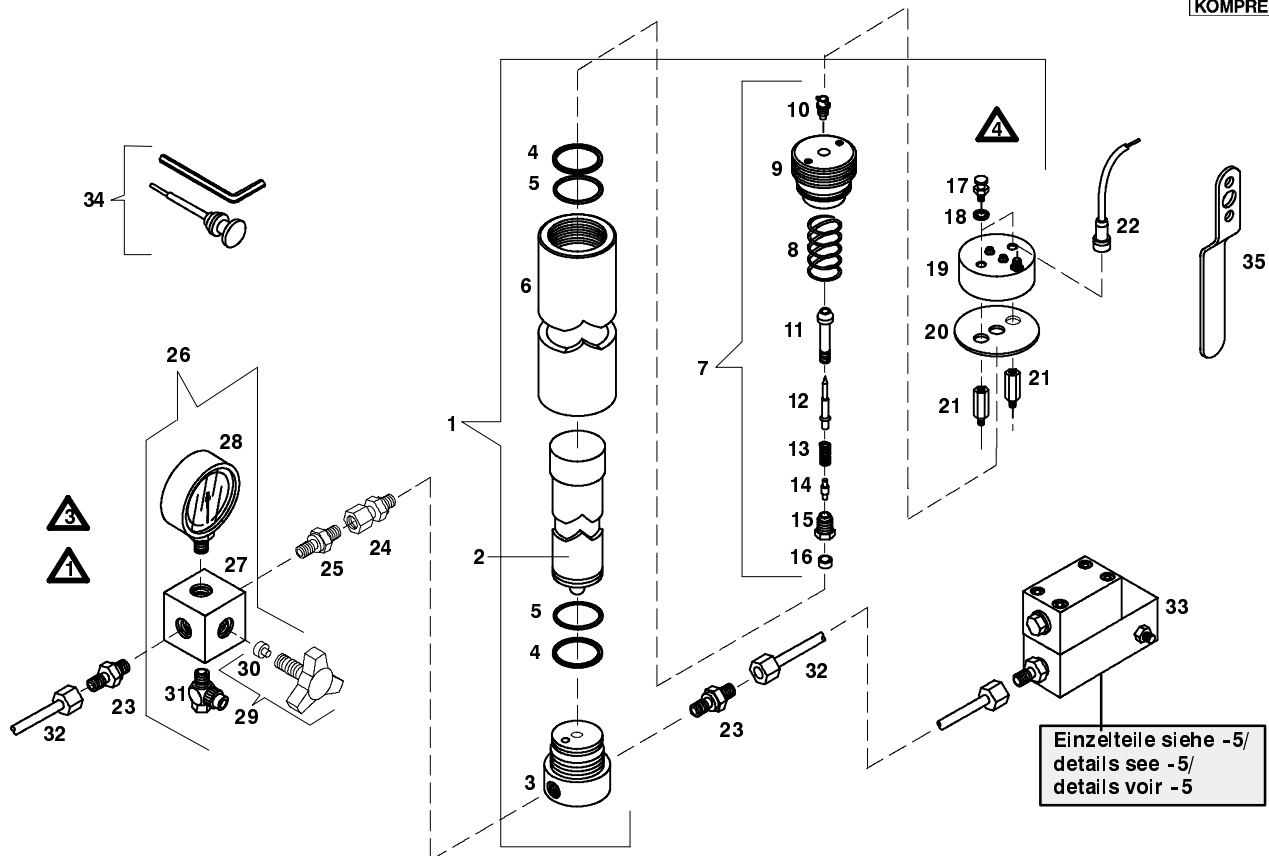
 Wartungsätze
 Maintenance kits
 Kits d'entretien

 Bildtafel
 Figure
 Planche

 B7.5- 4
 B7.5- 4
 B7.5- 4

 Feinnachreiniger m. SECURUS/COMP-TRONIC
 Purifier with SECURUS/COMP-TRONIC
 Epurateur avec SECURUS/COMP-TRONIC

Klasse/ Class/ Classe			Pos.	Bestell-Nr. Part No. No. de cde.	Anz. Qty. Qté.	Benennung	Designation	Dénomination	Gew. Weight Poids (kg)	Abmessungen Dimensions Dimensions
a	b	c								
			23	N16265	2	Gerade Rohrverschr.	Male connector	Raccord droit mâle		
			24	N15501	1	Einstellb. ger. Rohrv.	Adjust. male connector	Raccord droit mâle orient.		
			25	N4024	1	Gerade Rohrverschr.	Male connector	Raccord droit mâle		
			26	064566	1	Entlüftungsventil	Venting valve	Clapet de décharge		
			27	64486	1	Ventilkörper	Valve body	Corps de clapet		
			28	N16872	1	Manometer	Pressure gauge	Manomètre		
			29	065500	1	Knebelschraube kpl.	Petcock handle assy.	robinet cpl.		
X			30	64498	1	Dichtung	Gasket	Joint		
			31	N16334	2	L-Schnellverschraubung	Male run Tee	Raccord en T renversé		
			32	N3619**	1	Verbindungsleitung	Connecting tube	Conduite de connexion		
			33	063838	1	Druckhalte-/Rückschlagventil kpl.	Pressure maint./non-return valve assy.	Clapet de maint. ee press. anti-retour		
			34	067458	1	Werkzeugsatz f. Knebelschraube	Tool set for petcock handle	Jeu d'outils pour vis à robinet		
			35	60074	1	Schlüssel	Key	Clé		

**

Meterware

Piece goods; specify length upon order

Marchandise au mètre; indiquer la longueur à la commande

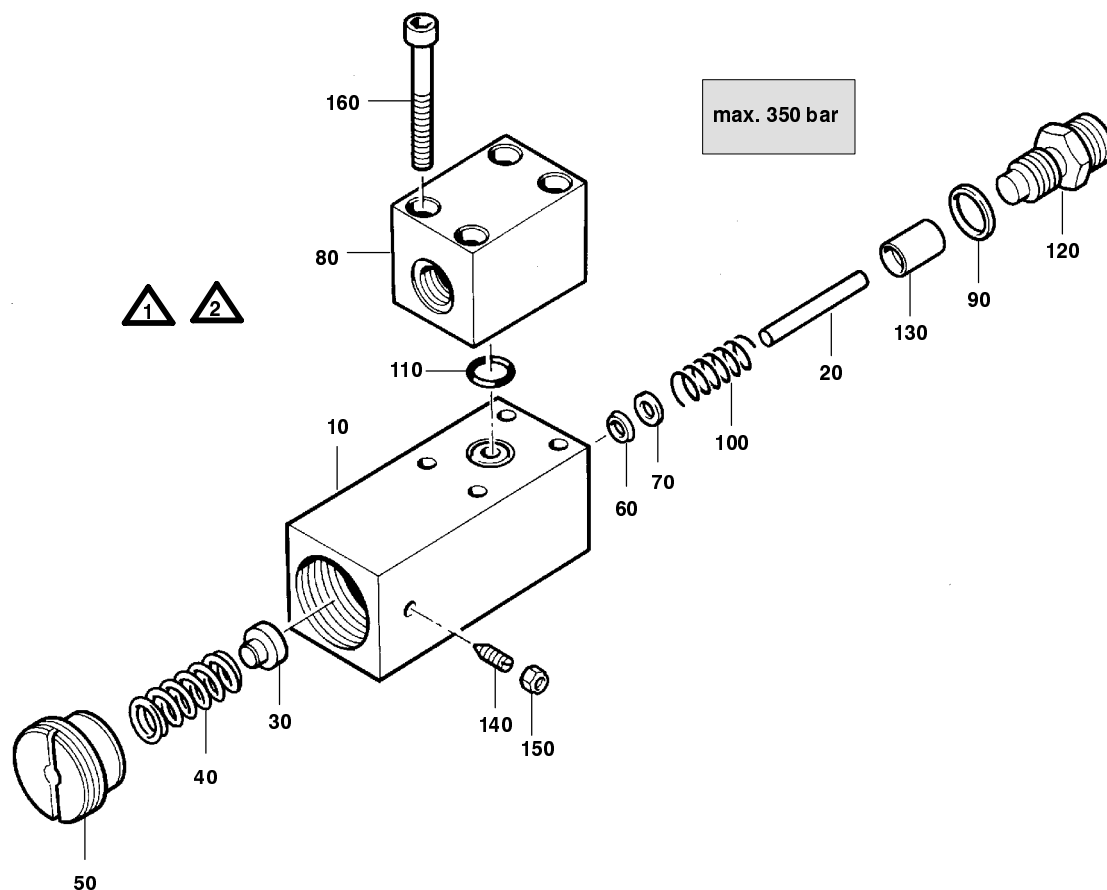
 Wartungssätze
 Maintenance kits
 Kits d'entretien

 Bildtafel
 Figure
 Planche

 B7.5- 5
 B7.5- 5
 B7.5- 5

 Druckhalte-Rückschlagventil
 pressure maintaining and non-return valve
 soupape de maintien de pression anti-retour

Klasse/ Class/ Classe			Pos.	Bestell-Nr. Part No. No. de cde.	Anz. Qty. Qté.	Benennung	Designation	Dénomination	Gew. Weight Poids (kg)	Abmessungen Dimensions Dimensions
a	b	c								
			10	90964	1	Ventilkörper				
	X		20	77245	1	Zylinderstift			5 g	DIN 7;5h8x40;Rz2-3
			30	57762	1	Aufnahme	spring seat	siege de ressort		f. Feder
			40	2623	1	Druckfeder	spring	ressort de pression		
			50	57935	1	Einstellschraube	adjusting screw	vis d'ajustage		
			60	N17080	1	Dichtung	gasket	joint		5x8x2.3;FU;PTFE
			70	90965	1	Scheibe				f. DH/RS-Ventil
			80	90967	1	Anschlußstück				
			90	N4602	1	USIT-Ring	usit-ring	joint usit		U 14-18.7-1.5;St/NBR
			100	N23206	1	Druckfeder				VD-063N
			110	N3824	1	O-Ring	o-ring	joint torique		7.59x2.62;NBR;70 Sh.
			120	90966	1	Ventilsitz				
			130	75269	1	Ventilkolben	valve piston	piston		
			140	N4465	1	Gewindestift	set screw	goujon filete	1 g	DIN 553;M4x10;5.8
			150	N3837	1	Sechskantmutter	hex nut	ecrou hex.		DIN 985;M4;8
			160	N724	4	Zylinderschraube	allen screw	vis a six pans creux	11 g	DIN 912;M6x40;8.8